

LJ系列 液压绞车

LJ Series Hydraulic Winch

产品目录 Catalogue

+	液压马达 Hydraulic Motor	
○	绞车（卷扬机） Winch	
➤	LJ系列 液压绞车 LJ Series Hydraulic Winch	8-10MPa
	MJ系列 液压绞车 MJ Series Hydraulic Winch	16-20MPa
	HJ系列 液压绞车 HJ Series Hydraulic Winch	24-30MPa
	DJ系列 电动绞车 DJ Series Electric Winch	
+	液压传动装置 Hydraulic Transmission Device	
+	其他 Others	

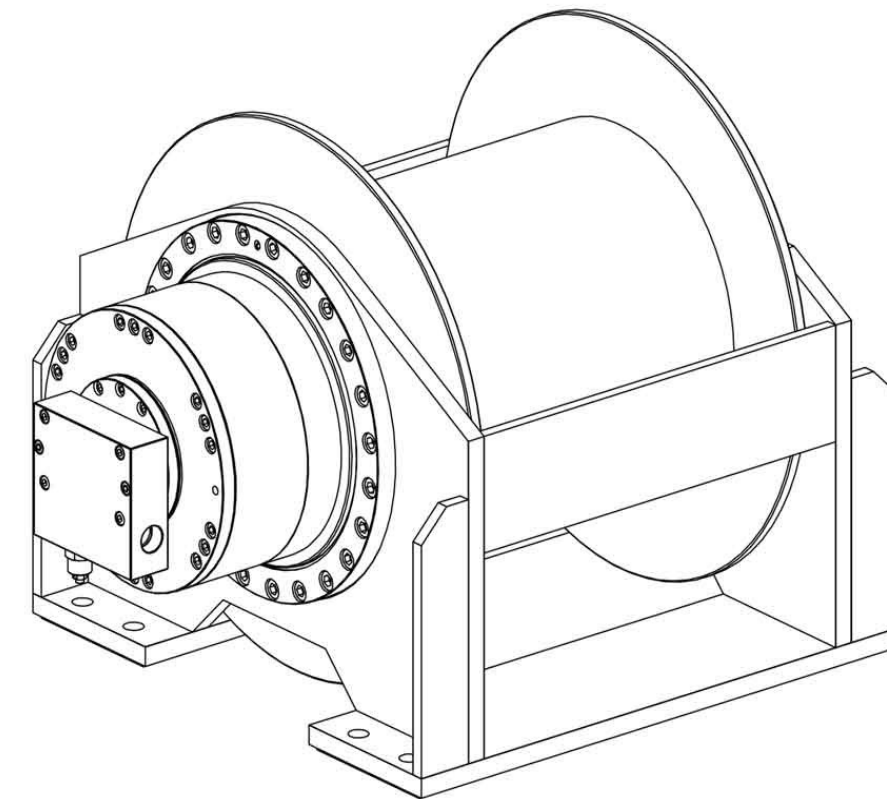













产品概述 / Brief Introduction

LJ系列液压绞车由液压马达、配流器、行星减速器、机架、卷筒及支承部组成。
液压马达采用径向柱塞式低速大扭矩马达，性能稳定可靠。
配流器默认含单向平衡阀和高压梭阀功能，用户只需配备液压泵站及换向阀即可。
行星减速机配备了常闭式制动器，由配流器上的高压梭阀引出控制油路打开刹车（控制油路出厂时已联接）。
机架和卷筒为钢结构件，卷筒末端的支承部，配备高承载能力的轴承，对卷筒进行支撑。
LJ系列液压绞车具有结构紧凑，起动效率高，低速稳定性好，传动效率高，低噪音，经济性好等特点，广泛应用于工程机械、建筑、铁路、公路、船舶、石油、煤矿、港口等领域的各种起重设备中。

LJ series hydraulic winches consist of hydraulic motor, distributor, planetary gearbox, frame, drum and supporting part.
The product uses radial ball plunger hydraulic motor, with stable and reliable performance.
The distributor consists of a one-way balance valve and a high-pressure shuttle valve by default. To run the winch, customers only need to provide hydraulic pump station and directional valve.
The planetary gearbox is equipped with normally closed brake, which is opened by the control oil circuit led out from the high-pressure shuttle valve port of the distributor.
The frame and drum are made of steel. The supporting part is equipped with bearings with high load capacity to support the drum.
LJ series hydraulic winches have the characteristics of compact structure, high starting efficiency, good low-speed stability, high transmission efficiency, low noise, good economy and so on. It is widely used in engineering machinery, construction, railway, highway, ship, petroleum, coal mine, port and other fields of lifting equipment.

型号说明 / Ordering Code

产品系列 / Series	LJ / MJ												
底层拉力 / Pull (KN)	5 / 10 / 20 / 25 160 / 180 / 200												
容量 / Cable Capacity (m)	详见参数表 / See Data Sheet												
钢丝绳直径 / Cable Diameter (mm)	详见参数表 / See Data Sheet												
出绳方向 / Cable Output Direction	<table border="1"> <tr> <td></td> <td>逆时针转动，上出绳 / Counterclockwise Drum Rotation with Cable Exit Over Drum</td> <td>CC1</td> </tr> <tr> <td></td> <td>逆时针转动，下出绳 / Counterclockwise Drum Rotation with Cable Exit Under Drum</td> <td>CC2</td> </tr> <tr> <td></td> <td>顺时针转动，上出绳 / Clockwise Drum Rotation with Cable Exit Over Drum</td> <td>C1</td> </tr> <tr> <td></td> <td>顺时针转动，下出绳 / Clockwise Drum Rotation with Cable Exit Under Drum</td> <td>C2</td> </tr> </table>		逆时针转动，上出绳 / Counterclockwise Drum Rotation with Cable Exit Over Drum	CC1		逆时针转动，下出绳 / Counterclockwise Drum Rotation with Cable Exit Under Drum	CC2		顺时针转动，上出绳 / Clockwise Drum Rotation with Cable Exit Over Drum	C1		顺时针转动，下出绳 / Clockwise Drum Rotation with Cable Exit Under Drum	C2
	逆时针转动，上出绳 / Counterclockwise Drum Rotation with Cable Exit Over Drum	CC1											
	逆时针转动，下出绳 / Counterclockwise Drum Rotation with Cable Exit Under Drum	CC2											
	顺时针转动，上出绳 / Clockwise Drum Rotation with Cable Exit Over Drum	C1											
	顺时针转动，下出绳 / Clockwise Drum Rotation with Cable Exit Under Drum	C2											
选装配置 / Optional	<table border="1"> <tr> <td>无选装配置 / Without Optional Requirements</td> <td>省略 / No Letters</td> </tr> <tr> <td>带自动排绳器 / With Automatic Cable Arrangement Device</td> <td>CA</td> </tr> <tr> <td>带压绳器 / With Cable Tensioner</td> <td>CT</td> </tr> <tr> <td>带自由下放功能 / With the Function of Free Fall</td> <td>FF</td> </tr> </table>	无选装配置 / Without Optional Requirements	省略 / No Letters	带自动排绳器 / With Automatic Cable Arrangement Device	CA	带压绳器 / With Cable Tensioner	CT	带自由下放功能 / With the Function of Free Fall	FF				
无选装配置 / Without Optional Requirements	省略 / No Letters												
带自动排绳器 / With Automatic Cable Arrangement Device	CA												
带压绳器 / With Cable Tensioner	CT												
带自由下放功能 / With the Function of Free Fall	FF												

型号举例 / Ordering Code Example

例1: LJ40-57/16-CC1-CA
表示该液压绞车底层拉力40KN, 卷筒容量57m, 钢丝绳直径16mm, (站在马达端看) 卷筒逆时针旋转时上方出绳, 选装了自动排绳器功能。

例2: LJ140-78/30-C2
表示该液压绞车底层拉力140KN, 卷筒容量78m, 钢丝绳直径30mm, (站在马达端看) 卷筒顺时针旋转时下方出绳, 无其他选装功能。

Example 1: LJ40-57/16-CC1-CA
It means that pull of the hydraulic winch in the bottom layer is 40kN, the cable capacity of the drum is 57m, and the diameter of the steel cable is 16mm. (standing at the side of the hydraulic motor), when the drum rotates counterclockwise, the cable is pulled out above the drum, and the automatic cable arrangement device is installed.

Example 2: LJ140-78/30-C2
It means that pull of the hydraulic winch in the bottom layer is 140kN, the cable capacity of the drum is 78m, and the diameter of the steel cable is 30mm. (standing at the side of the hydraulic motor), when the drum rotates clockwise, the cable is pulled out below the drum, and there are no other optional requirements.

参数说明 / Parameter Description

- 总排量: 是液压马达排量与行星减速器传动比的乘积, 同时也是卷筒转一圈所需的理论供油量。
 - 供油流量: 是考虑液压马达容积效率后, 绞车所需的实际供油量。
 - 容量: 为绞车的理论容量。实际工作中, 至少在卷筒上保留3圈缠绕钢丝绳, 以防止绳头脱出。
- Total Displacement: It is the displacement of the hydraulic motor multiplied by the transmission ratio of the planetary gearbox, and it is also the theoretical oil supply for one revolution of drum.
 - Oil Supply Flow: It is the actual oil supply required by the hydraulic winch after considering the volumetric efficiency of the hydraulic motor.
 - Cable Capacity: It is the theoretical capacity of winch. In practical work of winch, at least 3 circles of winding cable should be reserved on the drum to prevent the cable head from falling out.

使用说明 / Instructions

- 绞车不允许作载人使用。
- 吊钩或负载下方禁止站人。
- 请将绞车安装固定在足够强度的平整面上。
- 绞车提升(收绳)旋转默认为顺时针方向, 见样本附图。若需改变提升旋转的方向, 请在订货时说明。
- 不得通过改变钢丝绳缠绕方向, 来随意改变提升旋向, 此举具有危险性。
- 绞车工作过程中, 为防止绳头脱出, 卷筒上至少保留3圈钢绳。
- 初次启动前, 请通过泄油口向马达壳体内注满液压油。
- 泄油口需直接接到油箱, 马达壳体允许最高压力0.5MPa。
- 请使用高质量、防泡沫、抗氧化的矿基液压油, 一般建议46号液压油。
- 理想工作油温为30°C~50°C, 允许油温为-20°C~80°C。当油温低于10°C时, 必须使用低凝液压油。
- 液压油的粘度推荐40~60厘沱, 允许为5~3000厘沱。
- 液压油过滤精度推荐为25μm, 或更高过滤精度。
- 用户如有超功率使用要求, 请提前与厂家联系。

- The winch is not allowed to carry people.
- It is not allowed to stand under the hook or load.
- Please fix the winch on a flat surface with enough strength.
- The winch hoisting rotation is clockwise by default, see the sample attached figure. If customers need to reverse direction, please explain when ordering.
- It is not allowed to change the hoisting rotation direction by changing the winding direction of the steel cable, which is dangerous.
- At least 3 circles of winding cable should be reserved on the drum to prevent the cable head from falling out.
- Before the initial start, please fill the hydraulic motor shell with hydraulic oil through the drain port.
- The oil drain port shall be directly connected to the oil tank, and the maximum allowable pressure of hydraulic motor shell shall be 0.5MPa.
- Please use high quality mineral-based hydraulic oil, which is anti-wear, anti-foam and anti-oxidation.
- The ideal oil temperature is between 30 °C and 50 °C. The allowable oil temperature is between -20 °C and 80 °C. When the oil temperature is lower than 10 °C, please use low-freezing hydraulic oil.
- The oil viscosity is between 40cSt and 60cSt, and the allowable viscosity is between 5cSt and 3000cSt.
- It is recommended to use hydraulic oil with a filter rating of 25μm or even higher.
- If customers require over power operation, please contact us in advance.

LJ05/10

Jinghan

0.5-1T绞车

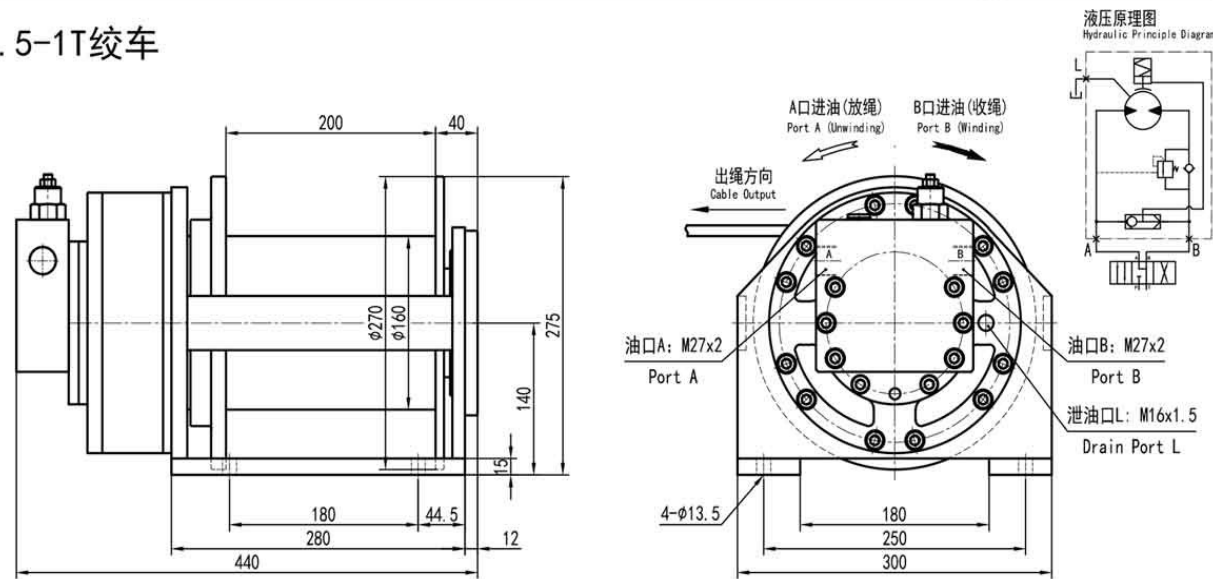

型号 Model	第一层 1st Layer		总排量 Displacement (ml/rev)	工作压差 Working Pressure (MPa)	供油流量 Oil Supply (L/min)	钢绳直径 Cable Diameter (mm)	容绳量 Cable Capacity (m)	减速比 Gear Ratio	重量 Weight (kg)
	拉力 Pull (KN)	绳速 Speed (m/min)							
LJ05-74/8-CC1	5	105	339	9	80	8	74	-	85
LJ10-47/10-CC1	10	55	664	8.7	80	10	47	-	85

LJ20/25/30

2-3T绞车

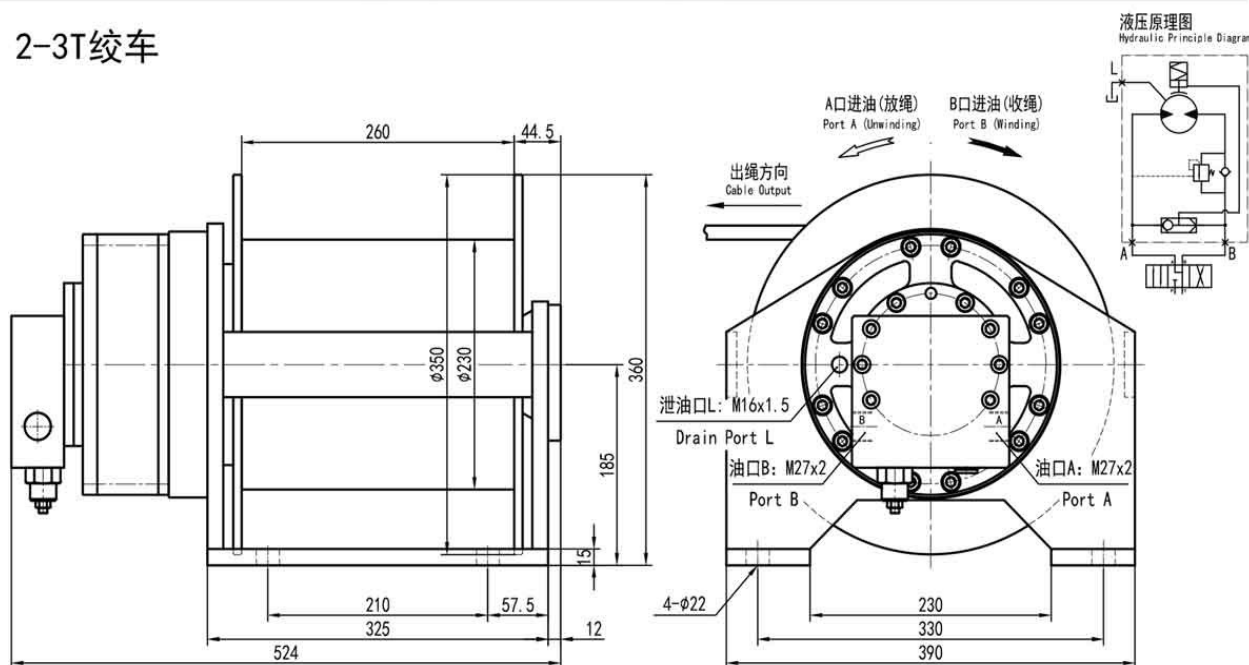

型号 Model	第一层 1st Layer		总排量 Displacement (ml/rev)	工作压差 Working Pressure (MPa)	供油流量 Oil Supply (L/min)	钢绳直径 Cable Diameter (mm)	容绳量 Cable Capacity (m)	减速比 Gear Ratio	重量 Weight (kg)
	拉力 Pull (KN)	绳速 Speed (m/min)							
LJ20-50/12-CC1	20	27	1898	9.8	80	12	50	5.6	145
LJ25-47/13-CC1	25	19	2778	7.8	80	13	47	5.6	145
LJ30-47/13-CC1	30	19	2778	9.4	80	13	47	5.6	145

LJ35/40/45

Jinghan

3.5-4.5T绞车

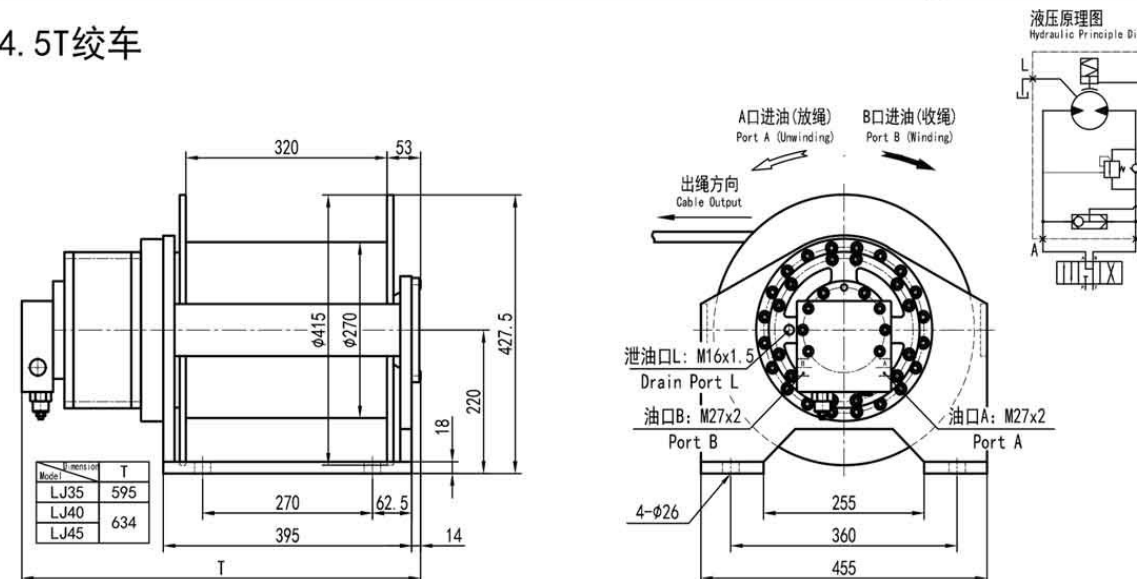

型号 Model	第一层 1st Layer		总排量 Displacement (ml/rev)	工作压差 Working Pressure (MPa)	供油流量 Oil Supply (L/min)	钢绳直径 Cable Diameter (mm)	容绳量 Cable Capacity (m)	减速比 Gear Ratio	重量 Weight (kg)
	拉力 Pull (KN)	绳速 Speed (m/min)							
LJ35-88/14-CC1	35	16	3718	9.5	80	14	88	5.6	210
LJ40-57/16-CC1	40	11	5600	7.3	80	16	57	5.6	220
LJ45-57/16-CC1	45	11	5600	8.2	80	16	57	5.6	220

LJ50/60/80

5-8T绞车

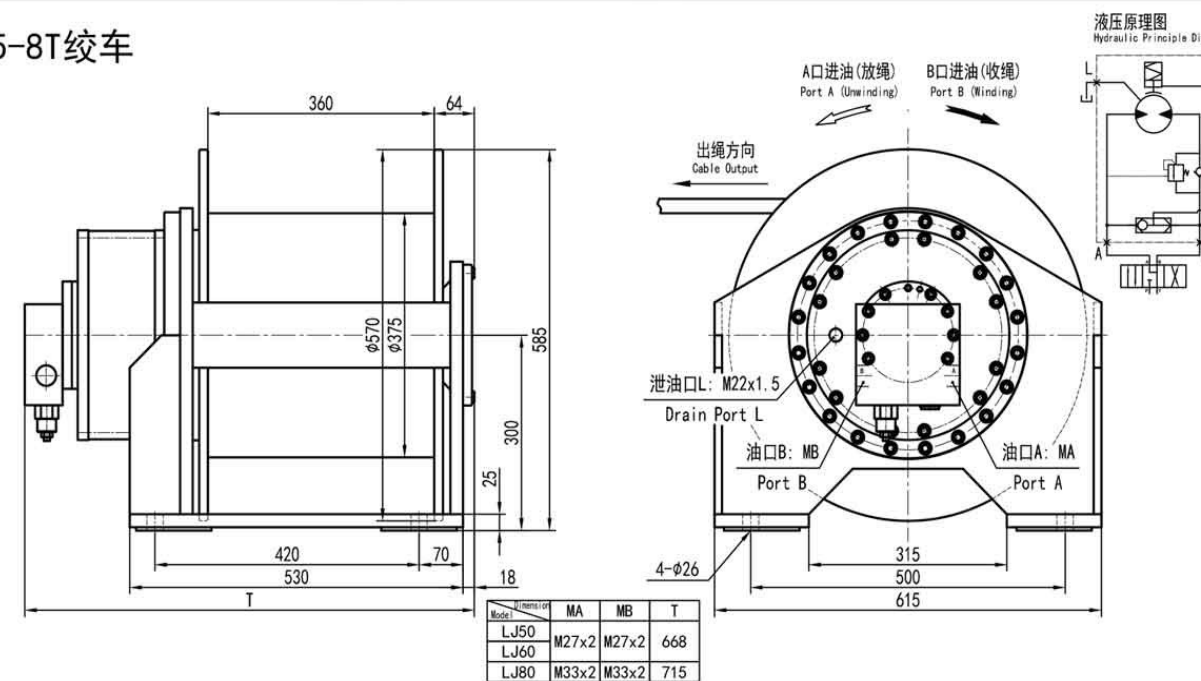

型号 Model	第一层 1st Layer		总排量 Displacement (ml/rev)	工作压差 Working Pressure (MPa)	供油流量 Oil Supply (L/min)	钢绳直径 Cable Diameter (mm)	容绳量 Cable Capacity (m)	减速比 Gear Ratio	重量 Weight (kg)
	拉力 Pull (KN)	绳速 Speed (m/min)							
LJ50-104/18-CC1	50	11	7582	9.2	80	18	104	5.6	420
LJ60-69/20-CC1	60	9	9240	9.2	80	20	69	5.6	420
LJ80-63/22-CC1	80	17	11368	10	180	22	63	5.6	460

LJ100/120/140

Jinghan

10-14T绞车

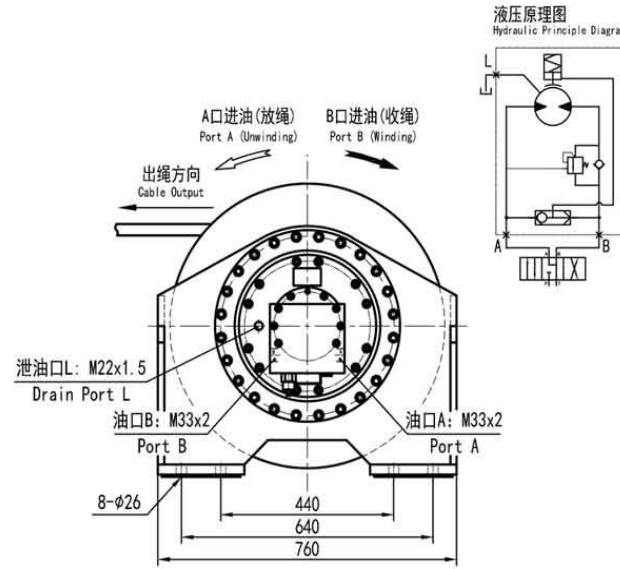
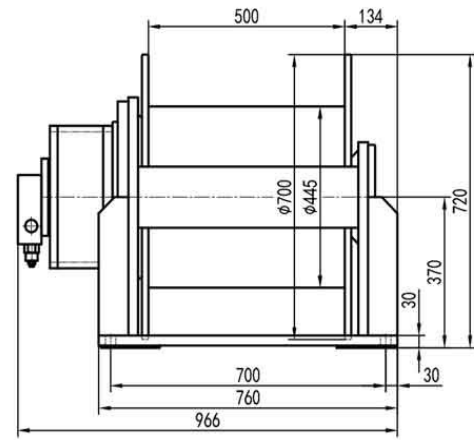

型号 Model	第一层 1st Layer		总排量 Displacement (ml/rev)	工作压差 Working Pressure (MPa)	供油流量 Oil Supply (L/min)	钢绳直径 Cable Diameter (mm)	容绳量 Cable Capacity (m)	减速比 Gear Ratio	重量 Weight (kg)
	拉力 Pull (KN)	绳速 Speed (m/min)							
LJ100-89/26-CC1	100	12	18480	9.1	180	26	89	5.6	850
LJ120-84/28-CC1	120	10	22400	9	180	28	84	5.6	850
LJ140-78/30-CC1	140	9	25760	9.2	180	30	78	5.6	880

LJ160/180/200

16-20T绞车

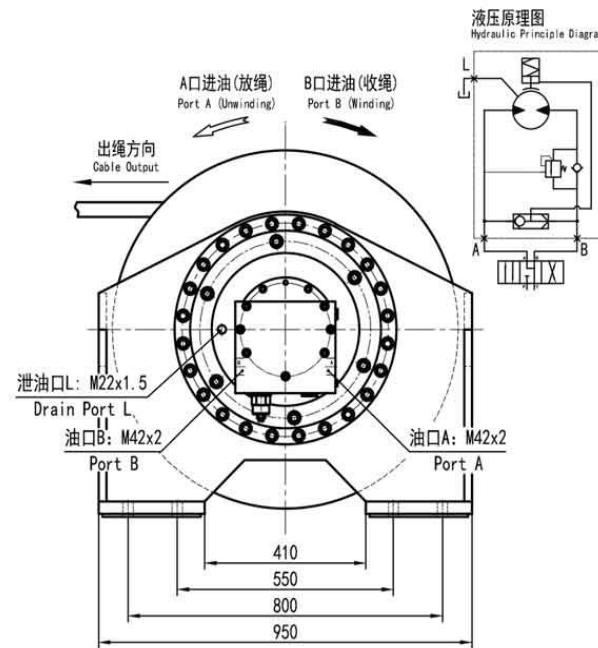
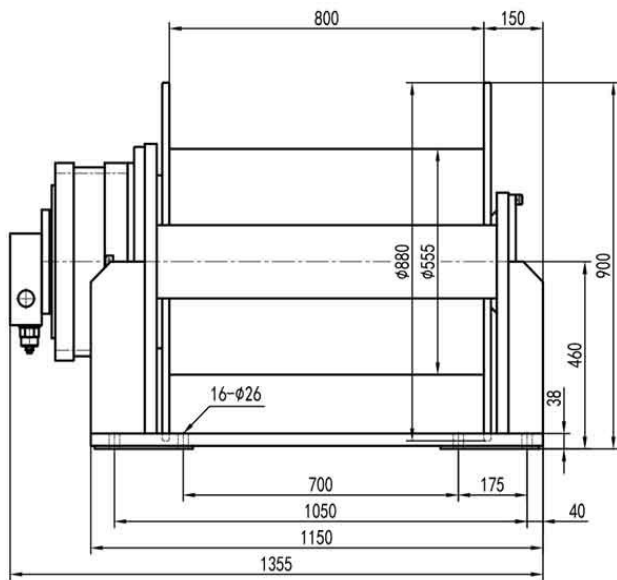

型号 Model	第一层 1st Layer		总排量 Displacement (ml/rev)	工作压差 Working Pressure (MPa)	供油流量 Oil Supply (L/min)	钢绳直径 Cable Diameter (mm)	容绳量 Cable Capacity (m)	减速比 Gear Ratio	重量 Weight (kg)
	拉力 Pull (KN)	绳速 Speed (m/min)							
LJ160-143/32-CC1	160	13	35616	9.4	300	32	143	5.6	1700
LJ180-136/34-CC1	180	11	43960	8.6	300	34	136	5.6	1800
LJ200-130/36-CC1	200	8.5	56840	7.4	300	36	130	5.6	1800